

LESA ARMOUR JOINT SYSTEMS

LESA ARMOUR JOINT TYPE G

SLIDING COVER PLATE JOINT

Type G provides a sliding cover plate joint system for a range of floors where high joint movement occurs due to the wide joint spacing. Type G is used in stressed slabs, jointless (high dosage) steel fibre slabs and shrinkage compensating concrete slabs. It has been in use since 2003. A robust cover plate slides over the joint as floor shrinkage occurs. Three versions (Types G45, G65, and G85) provide for expected joint width openings up to 85mm.

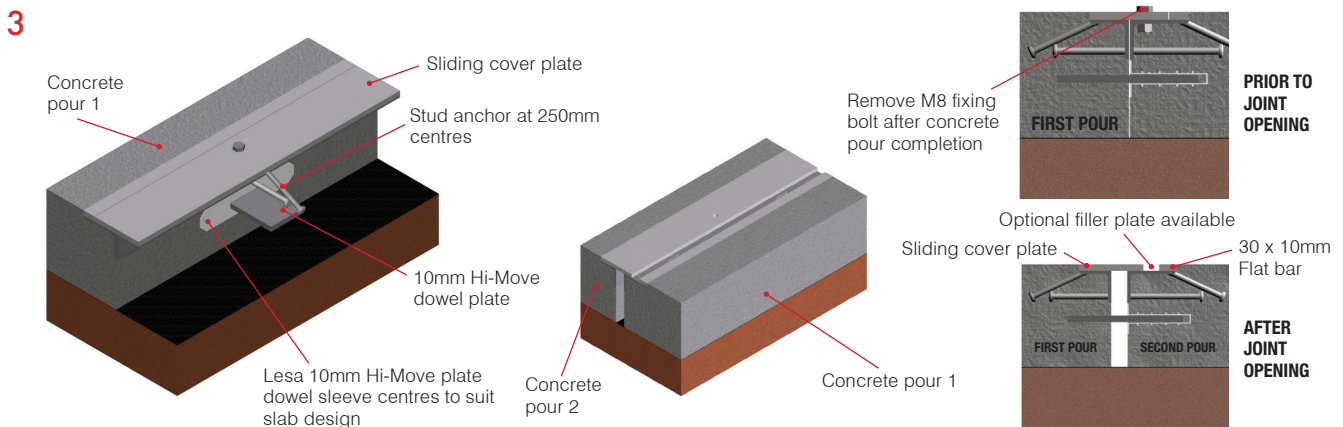
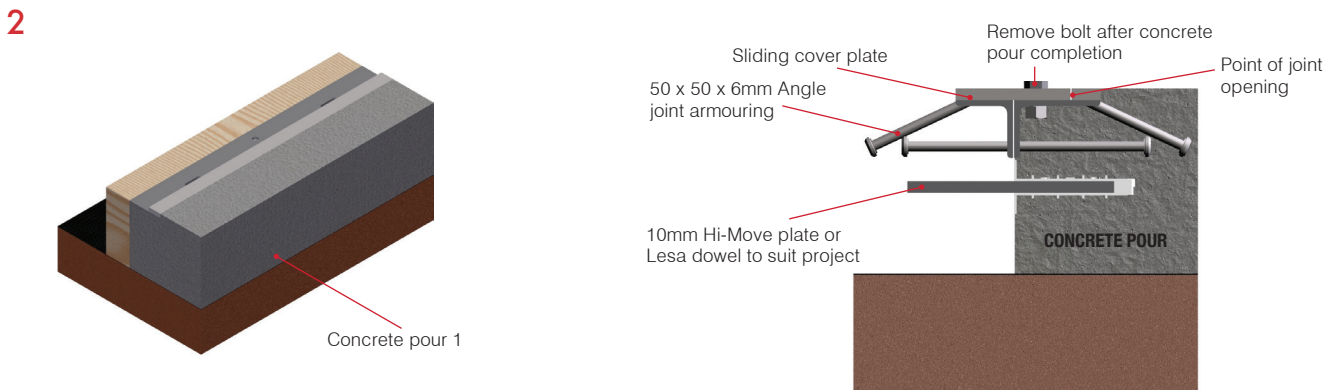
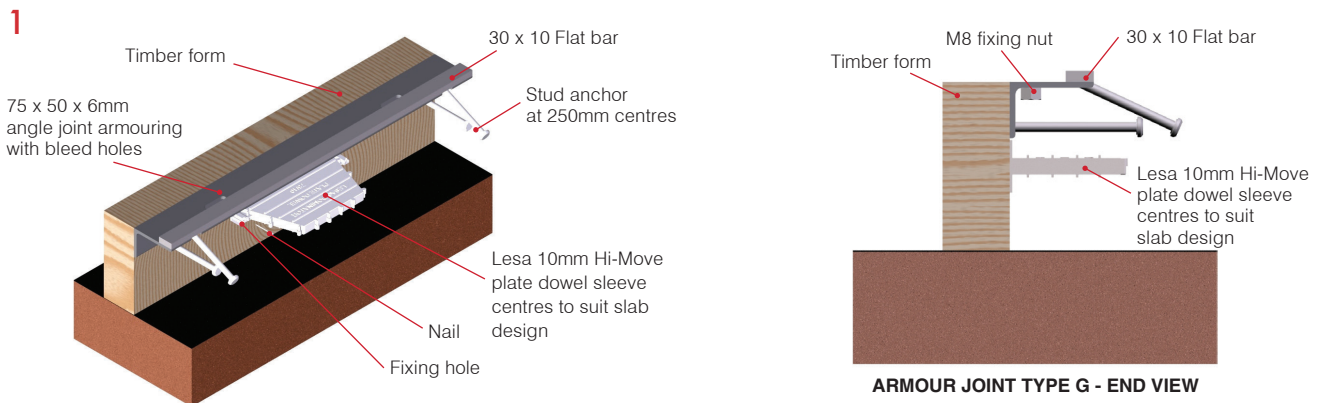

NOTE: Top mount bolt is optional and made to order. Steel sizes in above drawings are for Type G45.

LESA ARMOUR JOINT TYPE G-C

NEW TO EXISTING SLIDING COVER PLATE JOINT

Type G-C can be used where a new slab is poured against an existing slab, but a cover joint system is required. The first side is fabricated to enable it to be mounted into the edge of an existing slab.

1

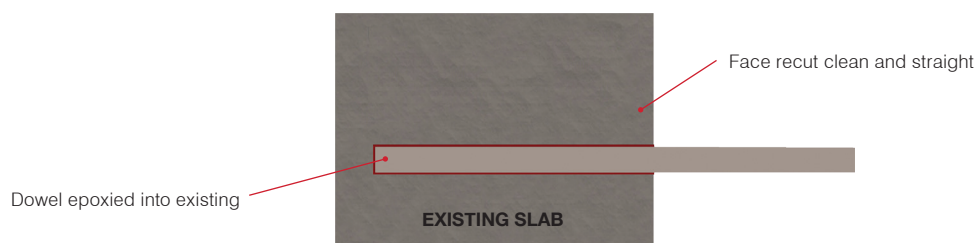

2

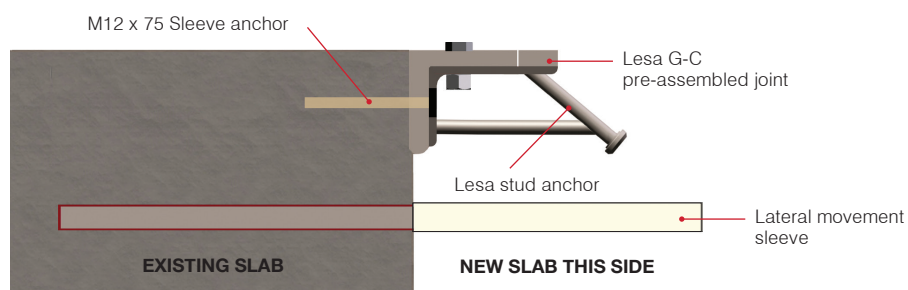

3

