

LESA ROUND DOWEL

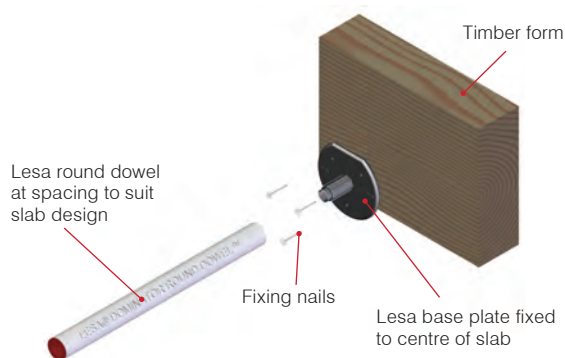

STEP 1: Mark the form for slab centre and sleeve spacing. Using three suitable nails or screws fix the sleeve base plate to the form.

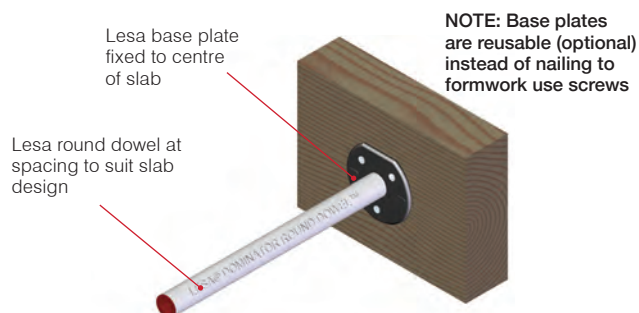

STEP 2: Set the form to line and level as normal. Slide the sleeve onto the base ensuring that it is flush with the base plate. Dowel support may be required to ensure the sleeve is not dislodged during placement.

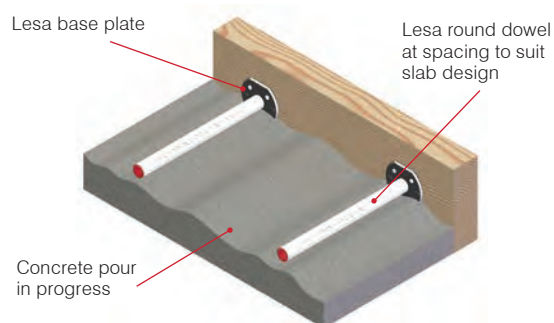

STEP 3: Place and finish the concrete. Edge of slab must be vibrated to consolidate concrete around the sleeve. (Care must be taken to ensure the sleeve is not dislodged).

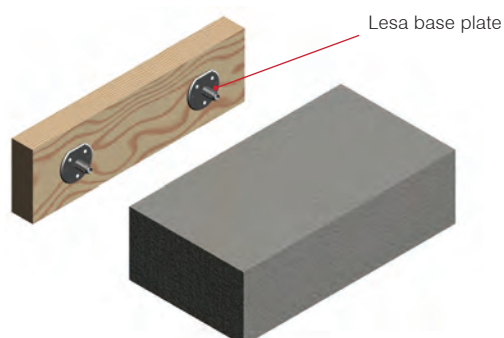

STEP 4: Strip the form. This is best accomplished by starting at one end and working along the form. Forms with base plates attached should be cleaned and stored for reuse.

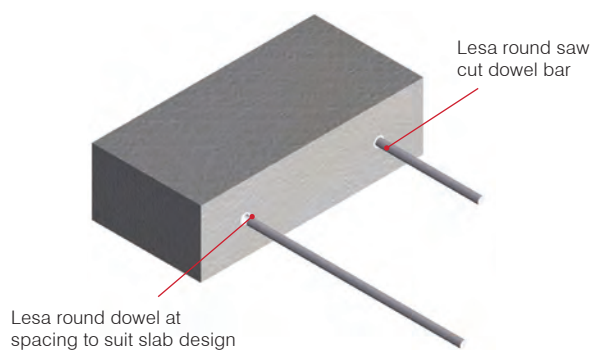

STEP 5: Insert the burr free end of the dowel bar into the Sleeve. Second concrete pour can now proceed.

