

## LESA TAPERED PLATE DOWEL

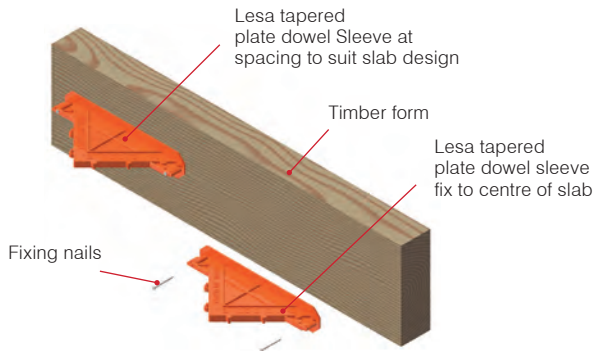

**STEP 1:** Mark the form for slab centre and tapered dowel sleeve spacing. Nail the sleeves to the form using the nails supplied in the sleeves.

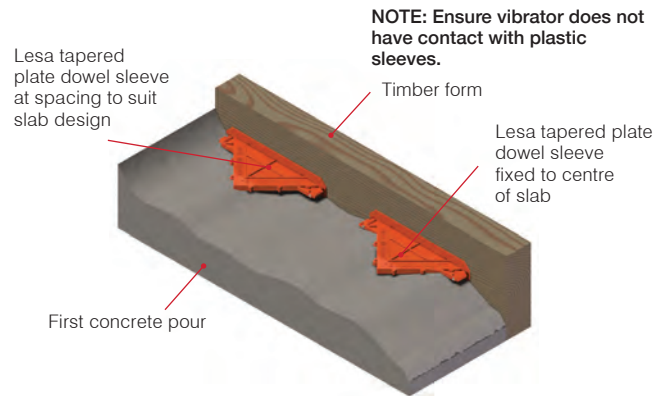

**STEP 2:** Set the form to line and level as normal and finish concrete. Edge of slab must be vibrated to consolidate concrete around the tapered dowel sleeve.

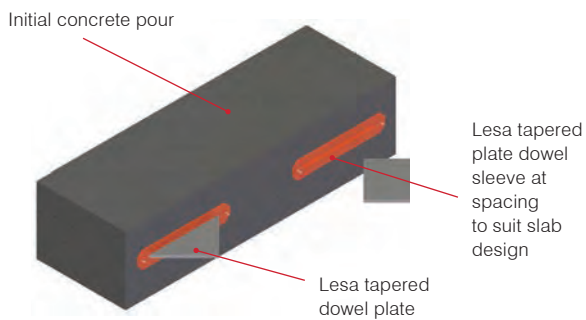

**STEP 3:** Strip the form. Forms should be cleaned and stored for reuse. Insert the tapered plate dowel when required prior to concrete pour.

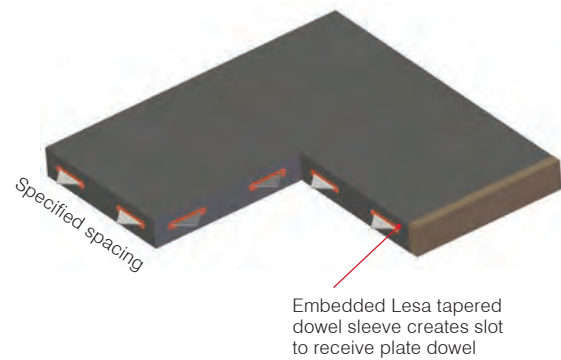

**STEP 4:** Pours proceed after plate installation.

