

LESA HI-MOVE SQUARE METAL DOWEL

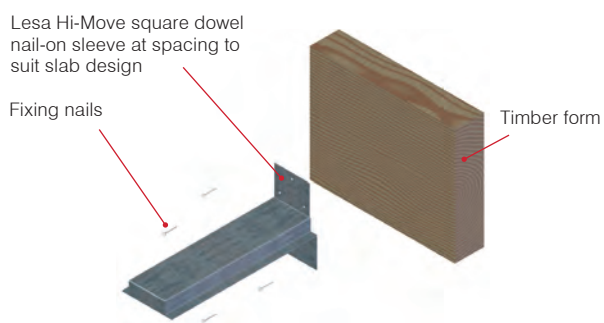

STEP 1: Mark the form for slab centre and nail-on sleeve spacing. Using four suitable nails or screws fix the HI-Move square dowel - sleeve to the form.

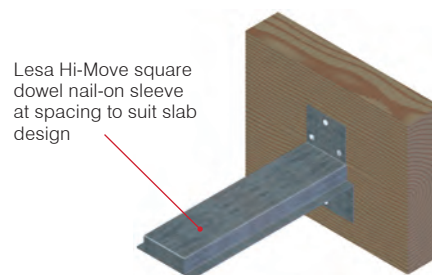

STEP 2: Set the form to line and level as normal.

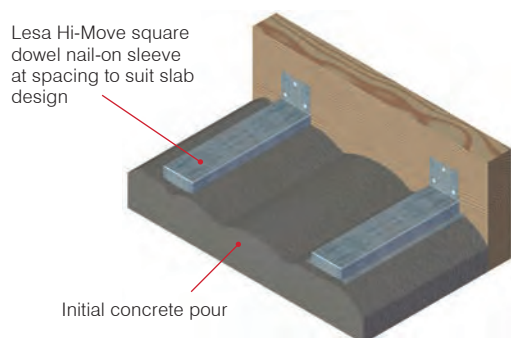

STEP 3: Place and finish the concrete. Edge of slab must be vibrated to consolidate concrete around the HI-Move square dowel.

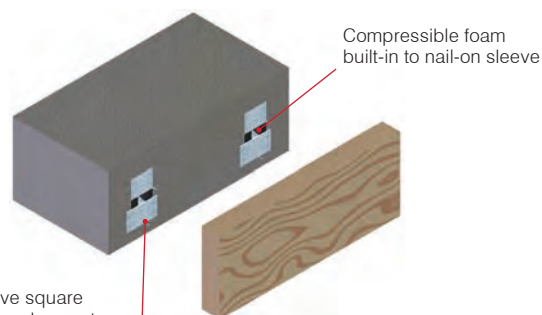

STEP 4: Strip the form. This is best accomplished by starting at one end and working along the form. Forms should be cleaned and stored for reuse.

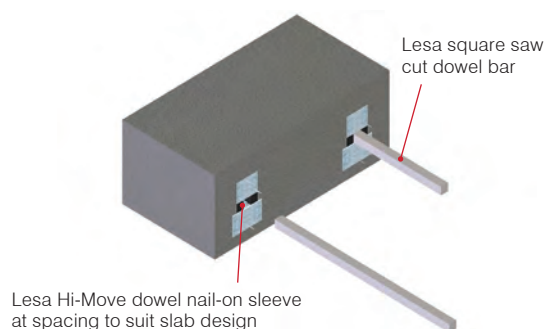

STEP 5: Insert the burr free end of the dowel bar into the nail-on sleeve. Second concrete pour can now proceed.